

Experiment 7: Hollow Lens

Required Equipment from Basic Optics System

Light Source

Hollow Lens from Ray Optics Kit

Box from Ray Optics Kit (with lenses and foam insert removed)

White Plastic Sheet from Ray Optics Kit

Other Equipment

Water

Paper towels

White paper

Small weight (to stop lens from floating)

Eye-dropper (optional, for removing water from the hollow lens)

Purpose

In this experiment you will explore how the properties of a lens are related to its shape, its index of refraction, and the index of refraction of the surrounding medium.

Background

A conventional lens is made of a material whose index of refraction is higher than that of the surrounding medium. For instance, the lenses in a pair of eyeglasses are usually made from glass or plastic with an index of refraction of 1.5 or higher, while the air surrounding the lenses has an index of refraction of 1.0. However, a lens can also have a *lower* index of refraction than the surrounding medium, as is the case when a hollow lens is “filled with air” and surrounded by water. (The index of refraction of water is about 1.3.)

The hollow lens in this experiment has three sections: a plano-concave section and two plano-convex sections. We will refer to these as sections 1, 2, and 3 (see Figure 7.1).

You will determine whether each section acts as a converging or diverging lens when it is *a)* filled with water and surrounded by air and *b)* filled with air and surrounded by water.

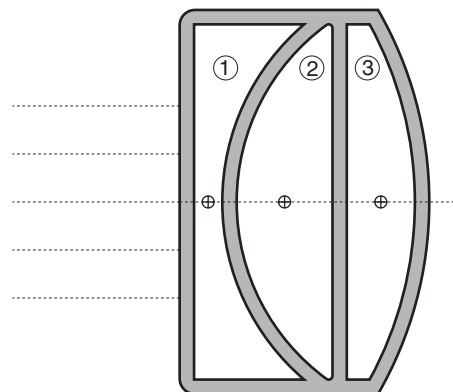

Figure 7.1: The hollow lens

Procedure

1. Before you test the hollow lens, make some predictions: For every configuration in Table 7.1, predict whether incoming parallel rays will converge or diverge after passing through the lens. Record your predictions in the table.
2. Place the light source in ray-box mode on a white sheet of paper. Turn the wheel to select five parallel rays.
3. Fill section 1 with water and place the lens in front of the light source so the parallel rays enter it through the flat side. Do the rays converge or diverge after passing through the lens? Record your observation in Table 7.1.

Repeat this step with water in different section of the lens to complete the first four rows of Table 7.1.

Table 7.1: Predictions and Observations

Lens surrounded by:	Section 1 filled with:	Section 2 filled with:	Section 3 filled with:	Prediction (converging or diverging)	Observation (converging or diverging)
Air	Water	Air	Air		
	Air	Water	Air		
	Air	Air	Water		
	Water	Air	Water		
Water	Air	Water	Water		
	Water	Air	Water		
	Water	Water	Air		

- Put the white plastic sheet in the transparent ray-optics box. Put the hollow lens in the box on top of the sheet as shown in Figure 7.2. Place a small weight on top of the lens to stop it from floating. Position the light source outside of the box so that the rays enter the hollow lens through the flat side.

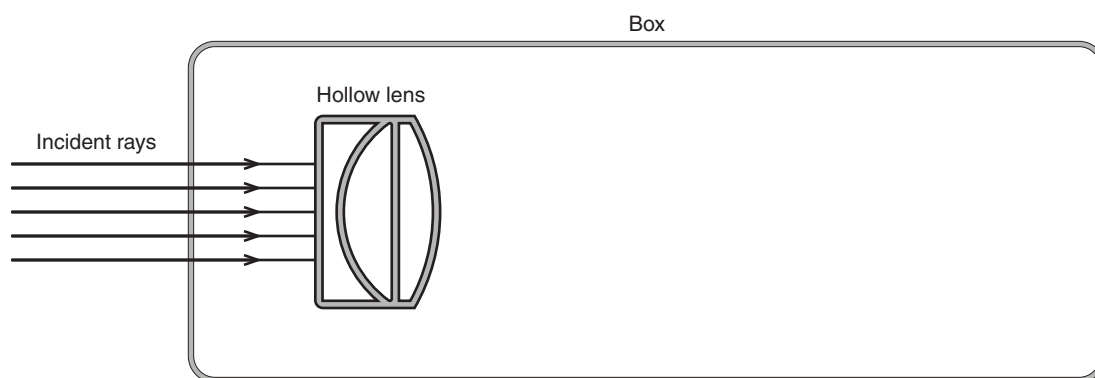

Figure 7.2: Hollow lens set up for testing surrounded by water

- Fill the box with water to just below the top of the lens. Fill sections 2 and 3 of the lens with water (leaving section 1 “filled” with air). Record your observation in Table 7.1.

Repeat this step with air in different section of the lens to complete Table 7.1.

Questions

- Under what conditions is a plano-convex lens converging? Under what conditions is it diverging?
- If a plano-concave lens of an unknown material is a diverging lens when surrounded by air, is it possible to know whether the lens will be converging or diverging when placed in water? Explain.