

Laboratory 13-2

Waves on a String

Equipment List:

- Science Workshop™ Interface
- Power Amplifier
- Balance (for measuring mass)
- graphing program (such as Microsoft Excel)
- Mass and Hanger Set
- meter stick
- (2) Patch Cords, banana plug
- Heavy String or twine, 20 meters
- Super Pulley
- Support Rod
- Table edge Clamp with smart pulley
- Wave Driver

PURPOSE

The purpose of this laboratory activity is to investigate standing waves in a string and to use the relationship between the tension in the string, the frequency of oscillation, the length of the string, and the number of segments in the standing wave to find the linear mass density of the string.

THEORY

When a stretched string is plucked it will vibrate in its fundamental mode in a single segment with nodes on each end. If the string is driven at this fundamental frequency, a standing wave is formed. Standing waves also form if the string is driven at any integer multiple of the fundamental frequency. These higher frequencies are called the harmonics.

Each segment is equal to half a wavelength. In general for a given harmonic, the wavelength is shown by $\lambda = 2L/n$ where **L** is the length of the stretched string and **n** is the number of segments in the string.

The linear mass density of the string can be directly measured by weighing a known length of the string: $\mu = \text{mass/length}$

The linear mass density of the string can also be found by studying the relationship between the tension, frequency, length of the string, and the number of segments in the standing wave. To derive this relationship, the velocity of the wave is expressed in two ways.

The velocity of any wave is given by where f is the frequency of the wave. For a stretched string:

$$v = \lambda f$$

$$v = \frac{2Lf}{n}$$

The velocity of a wave traveling in a string is also dependent on the tension, **T**, in the string and the linear mass density, **μ**, of the string:

$$v = \sqrt{\frac{T}{\mu}}$$

Setting these two expressions for the velocity equal to each other and solving for tension gives:

$$T = (4L^2 f^2 \mu) \left(\frac{1}{n^2} \right)$$

If the tension is varied while the length and frequency are held constant, a plot of tension vs. $(1/n^2)$ will give a straight line which will have a slope equal to $4L^2 f^2 \mu$. After the slope has been determined, the linear mass density of the string can be calculated.

The equation for the tension can also be solved for the frequency:

$$f = \sqrt{\frac{T}{4L^2 \mu}} n$$

If the frequency is varied while the tension and the length are held constant, a plot of frequency vs. number of segments will give a straight line. The slope of this line can be used to calculate the linear mass density of the string.

INTRODUCTION

In the Pre-Lab for this activity, you will determine the linear mass density of the string. The Procedure for this activity has two parts. In the first part, you will use different hanging masses to vary the tension of a string while the length and frequency are kept constant. You can plot a graph of tension vs. $1/n^2$ to determine the linear mass density of the string. In the second part, you will use the wave driver to vary the frequency while the length and tension are kept constant. The *Science Workshop* program controls the frequency of the wave driver. You can plot a graph of frequency vs. n to determine the linear mass density of the string.

The values of linear mass density for all three methods will be compared.

PRE-LAB

Direct Calculation of the Linear Mass Density

1. Measure the mass of a known length (about 20 m) of the string.

Length = $L =$ _____ Meters

Mass = $M =$ _____ Kilograms

2. Calculate the linear mass density by dividing the mass by the length ($\mu = \text{Mass/Length}$):
Record this value in Table 3.

PROCEDURE

In the first part of the Procedure for this activity, use different hanging masses to change the tension in the string. Use the *Science Workshop* program to keep the wave driver frequency at a constant value. In the second part of the Procedure, use the *Science Workshop* program to change the wave driver frequency.

A: Vary Tension – Constant Frequency and Length

PART IA: Computer Setup

1. Connect the *Science Workshop* interface to the computer, turn on the interface, and turn on the computer.
2. Connect the Power Amplifier DIN plug into Analog Channel A of the interface.
3. Connect a set of red and black leads from the output of the Power Amplifier to the input of the wave driver.
3. Within the software, connect the Power Amplifier to Analog Channel A
 - A document will open with a Signal Generator window.
 - You can change both the frequency and the amplitude of the wave. It is done by clicking the buttons next to the frequency and amplitude readouts. Your instructor will help you with this step if you need it. You will now be able to control the wave driver by using the computer as a control center.
3. Set the Signal Generator to **Auto**. The Signal Generator output will then begin when you click START and will stop when you click STOP.
 - There is no data display for this experiment.

PART IIA: Sensor Calibration and Equipment Setup

- You do not need to calibrate the Power Amplifier.
1. To avoid overloading the equipment, do not turn on the power switch of the power amplifier until the equipment setup is complete.
 2. Set up the equipment. Tie one end of a piece of string (a little longer than 2 meters) to a vertical support rod that is clamped to one end of a table. Pass the other end of the string over a pulley that is mounted on a rod that is clamped to the other end of the table. The goal here is that the length of string from the center of the wave driver pin to the center of the pulley should be approximately 2 m. It is necessary, however, that you know the precise value of this length (to the nearest millimeter). Tie a mass hanger to the end of the string that hangs over the pulley. Put about 500 grams on the mass hanger. Again, the precise value of the hanging mass must be known.
 3. Place the wave driver under the string near the vertical support rod. Insert the string in the slot on the top of the driver plug of the wave driver so the wave driver can cause the string to vibrate up and down. Note that the wave driver was already connected electrically to the Power Amplifier.

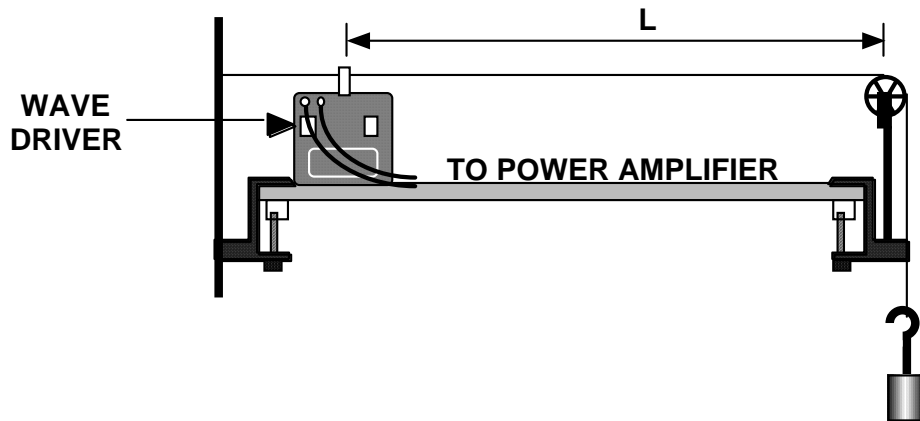

4. Use the meter stick to measure the length of the section of the string, L , that will be vibrating (the part between the driver plug of the wave driver and the top of the pulley). It has already been suggested that this value of L should be about 2 meters. Record the precise length in the Table 1.

PART IIIA: Data Recording – Vary Tension

1. Turn on the power switch on the back panel of the Power Amplifier.
2. Put enough mass on the mass hanger to make the string vibrate in its fundamental mode (one antinode in the center) **at a frequency of 60 Hz**. Adjust the amount of mass until the nodes at each end are very dark and “clean” (not vibrating). Record the initial mass in the Table 1. (Be sure to include the mass of the hanger.)
3. Now change the amount of mass on the mass hanger until the string vibrates in each of the higher harmonics (for 2 segments through 8 segments) and record these masses in Table 1 section. *Hint: Decrease the mass to increase the number of segments.*

ANALYZING THE DATA: Vary Tension – Constant Frequency and Length

1. Calculate the tension for each different mass used (tension = mass in kilograms x ‘g’ where g = 9.8 Newtons per kilogram).
2. Plot on graph paper the **tension vs. $1/n^2$** .
3. Find the slope of the line on the tension vs. $1/n^2$ graph.
4. Using the slope, calculate the linear mass density of the string. Record it in Table 3.
5. Calculate the percent difference between this value and the directly measured value and record it in Table 3.

DATA: Vary Tension – Constant Frequency and Length

Table 1: Vary Tension

Constant frequency = _____ Hz

Constant length = _____ Meters

Segments, n	Mass (kg)	Tension, T (N)	$1/n^2$
1			1.00000
2			0.25000
3			0.11111
4			0.06250
5			0.04000
6			0.02778
7			0.02041
8			0.01563

Linear mass density = _____ kg/m

B: Vary Frequency – Constant Tension and Length

PART IB: Computer Setup

- Use the same setup as in the first part of this procedure.

PART IIB: Sensor Calibration and Equipment Setup

- Put 500 grams on the mass hanger. Calculate and record the tension in Table 2. (Don't forget to include the mass of the hanger itself when you do this calculation.)

PART IIIB: Data Recording – Vary Frequency

1. Vary the output frequency of the Signal Generator until the string vibrates in one segment (the fundamental frequency).

Frequency Adjustment

You can adjust the frequency of the output by using the cursor and clicking on the frequency “up-down” arrows. You can also enter a value from the keyboard. To type in a value from the keyboard, click once on the value of frequency. A small edit box will appear where you can type a new value. Press <return> or <enter> to accept the value. When using the cursor and mouse button to click on the up-down arrows next to the frequency value, the default change is 10 Hz per click. You can use modifier keys (Control, Option and Command or **CTRL** and **ALT**) to increase or decrease the amount of change per click.

Macintosh Key	Windows Key (s)	Δ frequency
Shift key	Shift key	100 Hz
No modifier key	No modifier key	10 Hz
Control key	Ctrl key	1 Hz
Option key	Alt key	0.1 Hz
Command key	Alt + Ctrl keys	0.01 Hz

2. Find the frequencies required for the higher harmonics ($n = 2$ through 7) and record these in Table 2.

ANALYZING THE DATA: Vary Frequency – Constant Tension and Length

1. Plot on graph paper the **frequency vs. number of segments**.
2. Find the slope of the line on the frequency vs. number of segments graph.
3. From the slope of the line, calculate the linear mass density of the string and record this value in Table 3.
4. Calculate the percent difference between this value and the direct measurement value and record in Table 3.

DATA: Vary Frequency – Constant Tension and Length

Table 2: Vary Frequency

Constant tension = _____ Newtons

Constant length = _____ Meters

Segments, n	Frequency (Hz)
1	
2	
3	
4	
5	
6	
7	
8	

Linear mass density = _____ kg/m

Table 3: Results

Method	Linear mass density	% difference
Direct		
Tension vs. $1/n^2$		
Frequency vs. n		

QUESTIONS

1. As the tension is increased, does the number of segments increase or decrease when the frequency is kept constant?
2. As the frequency is increased, does the number of segments increase or decrease when the tension is kept constant?

3. As the tension is increased, does the speed of the wave increase, decrease, or stay the same when the frequency is kept constant?

4. As the frequency is increased, does the speed of the wave increase, decrease, or stay the same when the tension is kept constant?

Problem for Thought

Give your answer to this question along with a mathematical explanation using the equation:

Hypothetical Question:

Suppose that String #1 is twice as dense as String #2, but both have the same tension and the same length. If each of the strings is vibrating in the fundamental mode, which string will have the higher frequency?